

---

*Comfort-Cire*® **Century**®  
SE Series

---

# Split System Heat Pump

RSH15xxS1A

## Instruction Manual

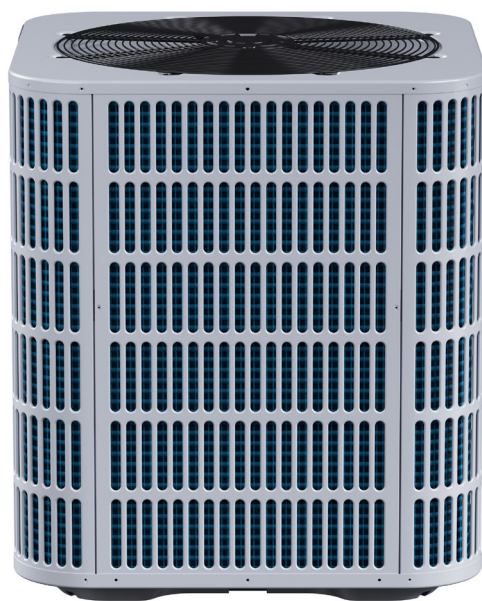

**MARS**®



**RECOGNIZE THIS SYMBOL AS AN INDICATION OF IMPORTANT SAFETY INFORMATION**

**⚠ WARNING**

These instructions are intended as an aid to qualified licensed service personnel for proper installation, adjustment and operation of this unit. Read these instructions thoroughly before attempting installation, or operation. Failure to follow these instructions may result in improper installation, adjustment, service, or maintenance possibly resulting in fire, electrical shock, property damage, personal injury, or death.

**⚠ WARNING**

This appliance is not intended for use by persons (including children) with reduced physical, sensory or mental capabilities, or lack of experience and knowledge, unless they have been given supervision or instruction concerning use of the appliance by a person responsible for their safety. Children should be supervised to ensure that they do not play with the appliance. This unit is only used outdoor.

**⚠ WARNING**

This product can expose you to chemicals including lead, which are known to the state of California to cause cancer and birth defects or other reproductive harm. For more information go to [www.p65Warnings.ca.gov](http://www.p65Warnings.ca.gov)

**💡 NOTE**

The manufacturer recommends installing only approved matched indoor and outdoor systems. All of the manufacturer's split systems are AHRI rated. Some of the benefits of installing approved matched indoor and outdoor split systems are maximum efficiency, optimum performance, and the best overall system reliability.

# CONTENTS

## 1 KEY TO SYMBOLS AND SAFETY INSTRUCTIONS

- 1.1 Key to Symbols..... 01
- 1.2 Safety ..... 01

## 2 UNIT LOCATION CONSIDERATIONS

- 2.1 Unit Dimensions ..... 02
- 2.2 Location Restrictions ..... 02

## 3 UNIT PREPARATION

- 3.1 Preinstallation ..... 03

## 4 SETTING UP THE UNIT

- 4.1 Pad Installation ..... 03

## 5 REFRIGERANT LINE CONSIDERATIONS

- 5.1 Service Valve Connection Sizes ..... 04
- 5.2 Refrigerant Line Sizes ..... 04
- 5.3 Refrigerant Piping Limits and Required Refrigerant Line Length ..... 04
- 5.4 Refrigerant Line Insulation ..... 04
- 5.5 Reuse Existing Refrigerant Lines ..... 05

## 6 REFRIGERANT LINE ROUTING

- 6.1 Precautions ..... 05

## 7 REFRIGERANT LINE BRAZING

- 7.1 Braze The Refrigerant Lines ..... 07

**8 REFRIGERANT LINE LEAK CHECK**

- 8.1 Check for Leaks ..... 08

**9 EVACUATION**

- 9.1 Evacuate the Refrigerant Lines and Indoor Coil ..... 08

**10 SERVICE VALVES**

- 10.1 Open the Service Valves ..... 09

**11 ELECTRICAL - LOW VOLTAGE**

- 11.1 Low Voltage Maximum Wire Length ..... 09
- 11.2 Low Voltage Hook-up Diagrams ..... 09

**12 ELECTRICAL - HIGH VOLTAGE**

- 12.1 High Voltage Power Supply ..... 11
- 12.2 High Voltage Disconnect Switch ..... 11
- 12.3 High Voltage Ground ..... 11

**13 START UP**

- 13.1 System Start Up ..... 12

**14 SYSTEM CHARGE ADJUSTMENT**

- 14.1 Charging: Weigh-In Method ..... 12
- 14.2 Suction Line Pressure Charging and Refrigerant Adjustment In Cooling  
(Above 55°F Outdoor Temp.) ..... 13

**15 SYSTEM OPERATION AND TROUBLESHOOTING**

- 15.1 Compressor Crankcase Heater (CCH) ..... 18
- 15.2 Reversing Valve ..... 18
- 15.3 Protection Function ..... 18
- 15.4 Defrost Mode ..... 18
- 15.5 Two-stage Compressor (61K HP only) ..... 19
- 15.6 Temperature Sensor Resistance Table ..... 19
- 15.7 Electrical Data Table ..... 20
- 15.8 Troubleshooting Table ..... 20
- 15.9 Fault Code Table ..... 20

**16 WARRANTY**

- 16.1 Maintenance ..... 21
- 16.2 Removing and Installing The Cover Plate ..... 21
- 16.3 Changing Motor ..... 22

**17 MATCHING TABLE AND CHECKOUT PROCEDURES**

- 17.1 Operational and Checkout Procedures ..... 22

# 1 KEY TO SYMBOLS AND SAFETY INSTRUCTIONS

## 1.1 Key to Symbols



Warnings in this document are identified by a warning triangle. Keywords at the start of a warning indicate the type and seriousness of the ensuing risks arising from failure to take measures.



This symbol indicates important information where there is no risk to people or property.

The following keywords are defined and can be used in this document:

**DANGER** indicates a hazardous situation which, if not avoided, will result in death or serious injury.

**WARNING** indicates a hazardous situation which, if not avoided, could result in death or serious injury.

**CAUTION** indicates a hazardous situation which, if not avoided, could result in minor to moderate injury.

**NOTICE** is used to address practices not related to personal injury.

## 1.2 Safety

Important - This document contains a wiring diagram and service information. This is customer property and is to remain with this unit. Please return to service information pack upon completion of work.



### CAUTION

This information is intended for use by individuals possessing adequate backgrounds of electrical and mechanical experience. Any attempt to repair a central air conditioning product may result in personal injury and/or property damage. The manufacturer or seller cannot be responsible for the interpretation of this information, nor can it assume any liability in connection with its use.



### WARNING

#### HAZARDOUS VOLTAGE!

Failure to follow this warning could result in property damage, severe personal injury or death. Disconnect all electric power, including remote disconnects before service. Follow proper lockout /tagout procedures to ensure the power cannot be inadvertently energized.

#### REFRIGERANT OIL!

Any attempt to repair a central air conditioning product may result in property damage, severe personal injury, or death.

These units use R-410a refrigerant which operates at 50% to 70% higher pressures than R-22. Use only R-410a approved service equipments. Refrigerant cylinders are painted a "Rose" color to indicate the type of refrigerant and may contain a "dip" tube to allow for charging of liquid refrigerant into the system. All R-410A systems use a POE oil (VG74 or equivalent) that readily absorbs moisture from the atmosphere. To limit this "hygroscopic" action, the system should remain sealed whenever possible. If a system has been open to the atmosphere for more than 4 hours, the compressor oil must be replaced. Never break a vacuum with air and always change the driers when opening the system for component replacement.

#### HIGH CURRENT LEAKAGE!

Failure to follow this warning could result in property damage, severe personal injury, or death. The ground connection should be connected before connecting electrical supply.

#### SERVICE VALVES!

Failure to follow this warning will result in abrupt release of system charge and may result in personal injury and/or property damage. Extreme caution should be exercised when opening the Liquid Line Service valve. Turn valve stem counter-clockwise only until the stem contacts the rolled edge. No torque is required.

#### BRAZING REQUIRED!

Failure to inspect lines or use proper service tools may result in equipment damage or personal injury. If using existing refrigerant lines make certain that all joints are brazed, not soldered.



### CAUTION

#### CONTAINS REFRIGERANT!

Failure to follow proper procedures can result in personal illness or injury or severe equipment damage. Systems contain oil and refrigerant under high pressure. Recover refrigerant to relieve pressure before opening a system.

#### GROUNDING REQUIRED!

Failure to inspect or use proper service tools may result in equipment damage or personal injury. Reconnect all grounding devices. Make sure all parts of this product that are capable of conducting electrical current are grounded. If grounding wires, screws, straps, clips, nuts, or washers used to complete a path to ground are removed for service, they must be returned to their original position and properly fastened.

#### HOT SURFACE!

May cause minor to severe burning. Failure to follow this caution could result in property damage or personal injury. Do not touch the top of the compressor.

## 2 UNIT LOCATION CONSIDERATIONS

### 2.1 Unit Dimensions

Unit Dimensions			
Model	H(inches)	W(inches)	L(inches)
18	24-15/16	23-5/8	23-5/8
24/30	24-15/16	28	28
36	33-3/16	28	28
42/48/60/61	33-3/16	29-1/8	29-1/8

Table 2-1

When mounting the outdoor unit on a roof, be sure the roof will support the unit's weight. Properly selected isolation is recommended to prevent sound or vibration transmission to the building structure.

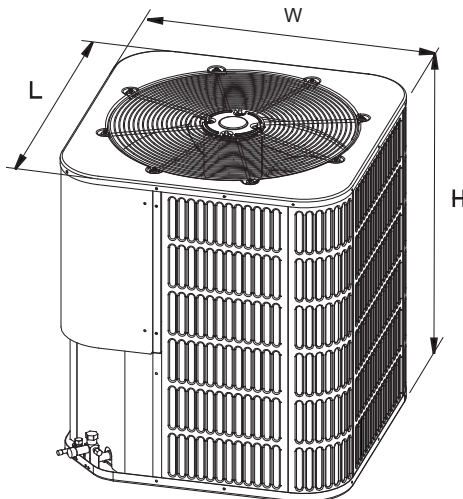

Figure 2-1

### 2.2 Location Restrictions

Ensure the top discharge area is unrestricted for at least 60 inches above the unit.

Do not locate outdoor unit near bedrooms since normal operational sounds may be objectionable.

Position unit to allow adequate space for unobstructed airflow, wiring, refrigerant lines, and serviceability.

Maintain a distance of 24 inches between units.

24 inches clearance must be provided in front of the control box (access panels) and any other side requiring service.

Position unit where water, snow or ice from roof or overhang cannot fall directly on unit.

Position the outdoor unit a minimum of 12" from any wall or surrounding shrubbery to ensure adequate airflow.

See Figure 2-2 and Figure 2-3

Cold climate considerations (heat pump only)

**NOTE**

Precautions must be taken for units being installed in areas where snow accumulation and prolonged below-freezing temperatures occur.

- Units should be elevated 3-12 inches above the pad or rooftop, depending on local weather. This additional height will allow drainage of snow and ice melted during defrost cycle prior to its refreezing. Ensure that drain holes in unit base pan are not obstructed, preventing drainage of defrost water (Fig. 2-4).
- If possible, avoid locations that are likely to accumulate snow drifts. If not possible, a snow drift barrier should be installed around the unit to prevent a build-up of snow on the sides of the unit.

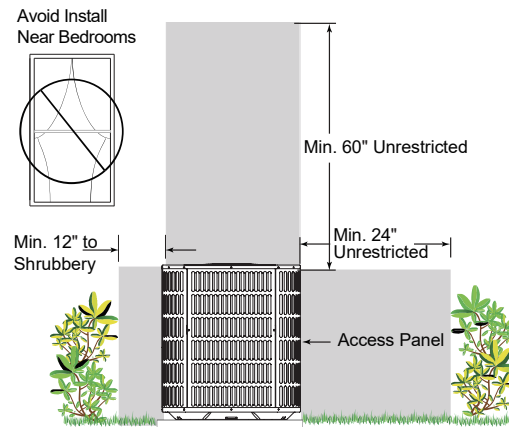

Figure 2-2

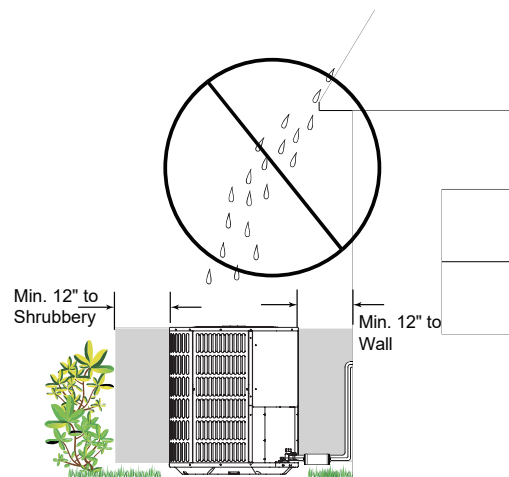

Figure 2-3

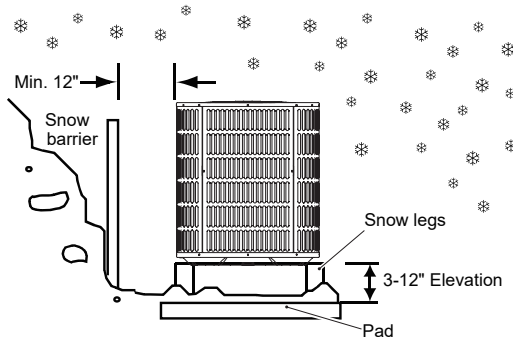

Figure 2-4

### 3 UNIT PREPARATION

#### 3.1 Preinstallation

STEP 1 - Check for damage and report promptly any damage found to the unit (Fig.3-1).

STEP 2 - Instruments must be designed to install/service R410A equipment.

- Gauge sets, hoses, refrigerant containers, and recovery system must be designed to handle the POE type oils.
- Manifold sets should be 800 PSIG high side and 250 PSIG low side.
- All hoses must have a 700 PSIG service pressure rating.
- Leak detectors should be designed to detect R410A.
- Recovery equipments (including refrigerant recovery containers) must be specifically designed to handle R410A.
- Do not use a R22 TXV.

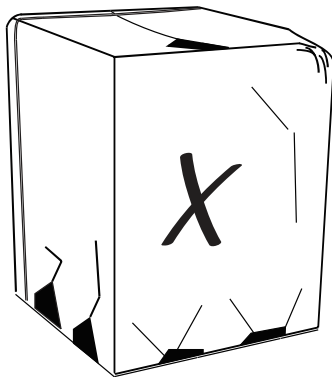

Figure 3-1

### 4 SETTING UP THE UNIT

#### 4.1 Pad Installation

When installing the unit on a support pad, such as a concrete slab, consider the following:

- The pad must be at least 1-2" larger than the unit on all sides.
- The pad must be separate from any structure.
- The pad must be level.
- The pad must be high enough above grade to allow for drainage.
- The pad location must comply with National, State and Local codes.

**NOTE**

These instructions are intended to provide a method to tie-down system to concrete slab as a securing procedure for high wind areas. Check Local Codes for tie-down methods and protocols.

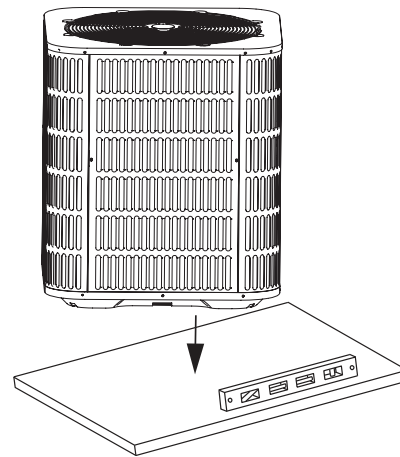

Figure 4-1

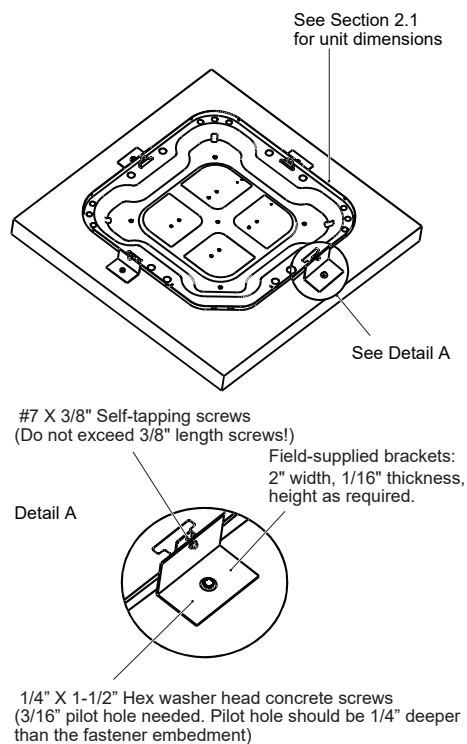

Figure 4-2

## 5 REFRIGERANT LINE CONSIDERATIONS

### 5.1 Service Valve Connection Sizes

Models	Suction line connection	Liquid line connection
18/24/30/36	3/4	3/8
42/48/60/61	7/8	

Table 5-1

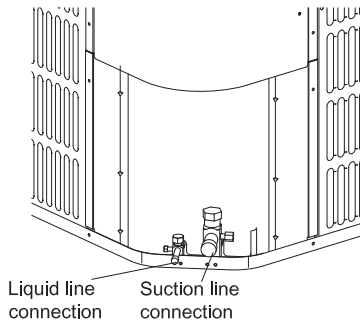

Figure 5-1

### 5.2 Refrigerant Line Sizes

Models	Suction Line		Liquid Line	
	optional	standard	optional	standard
18/24/30/36	5/8	3/4	5/16	3/8
42/48	3/4	7/8	1/2	
60/61	7/8	1-1/8	1/2	

Table 5-2

### 5.3 Refrigerant Piping Limits And Required Refrigerant Line Length

Model	Liquid line (inches)	Total equivalent length(Feet)					
		25	50	75	100	125	150
		Maximum vertical length(Feet)					
18	5/16	25	50	60	60	40	30
	3/8	25	50	60	60	40	30
24	5/16	25	40	30	20	15	10
	3/8	25	50	60	60	40	30
30	5/16	25	40	40	30	40	30
	3/8	25	50	60	60	40	30
36	5/16	25	50	40	30	10	NA
	3/8	25	50	60	60	40	30
42	5/16	25	23	4	N/A	NA	NA
	3/8	25	50	43	36	30	24
48	1/2	25	50	56	55	40	30
	3/8	25	46	38	30	22	15
60/61	1/2	25	50	60	60	40	30
	3/8	25	50	56	44	32	20

Table 5-3

Model	Suction (inches)	Total suction line length			
		25	50	100	150
		Coefficient			
18	5/8	1.00	0.97	0.94	0.90
	3/4	1.00	0.98	0.95	0.92
24	5/8	1.00	0.97	0.94	0.90
	3/4	1.00	0.98	0.95	0.92
30	5/8	1.00	0.97	0.94	0.90
	3/4	1.00	0.98	0.96	0.93
36	5/8	1.00	0.97	0.94	0.90
	3/4	1.00	0.99	0.97	0.96
42	3/4	1.00	0.98	0.95	0.93
	7/8	1.00	0.98	0.97	0.96
48	3/4	1.00	0.98	0.95	0.92
	7/8	1.00	0.98	0.97	0.96
60/61	7/8	1.00	0.98	0.94	0.90
	1 1/8	1.00	0.99	0.98	0.97

Table 5-4 Suction line length/size VS capacity multiplier

#### NOTE

Using suction line larger than shown in chart will result in poor oil return and is not recommended. For example: the system capacity published in AHRI is 17800 Btu/h. This data is based on the AHRI test condition and 25 feet line set with standard suction tube size (3/4" tube). If you need to add the line set more than 25 feet or use the optional suction tube size, you need to recalculate the capacity with the coefficient in the table. For 50 feet line and 5/8" suction tube, the capacity will be 17800\*0.97=17266 Btu/h.

Determine required line length and lift. You will need this later in Section 14.

Total Line Length = \_\_\_\_\_ Feet.

Total vertical Change(Lift) = \_\_\_\_\_ Feet.

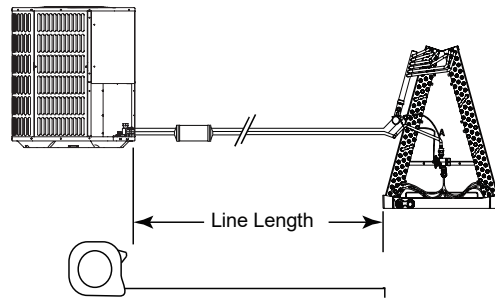

Figure 5-2

### 5.4 Refrigerant Line Insulation

#### NOTE

The suction line must always be insulated. DO NOT allow the Liquid Line and Suction Line to come in direct (metal to metal) contact.

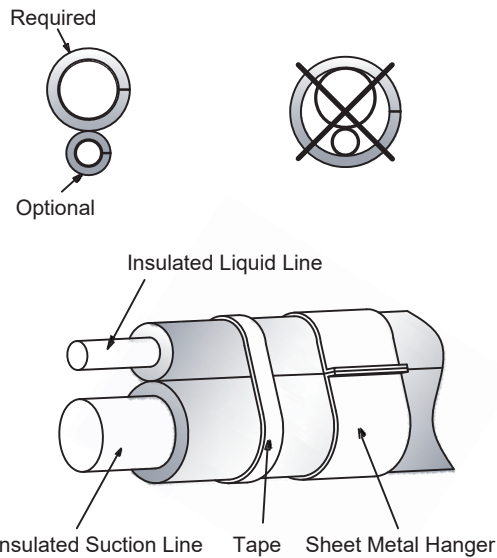

Figure 5-3

### 5.5 Existing Refrigerant Lines

**⚠ CAUTION**

If using existing refrigerant lines make certain that all joints are brazed, not soldered.

For retrofit applications, where the existing refrigerant lines will be used, the following precautions should be taken:

- Ensure that the size of the refrigerant lines is correct. Refer to Section 5.2 and Table 5-2.
- Ensure that the refrigerant lines are free of leaks, acid, and oil.

**💡 NOTE**

The manufacturer recommends installing only approved matched indoor and outdoor systems. All of the manufacturer's split systems are AHRI certified. Some of the benefits of installing approved matched indoor and outdoor split systems are maximum efficiency, optimum performance and the best overall system reliability.

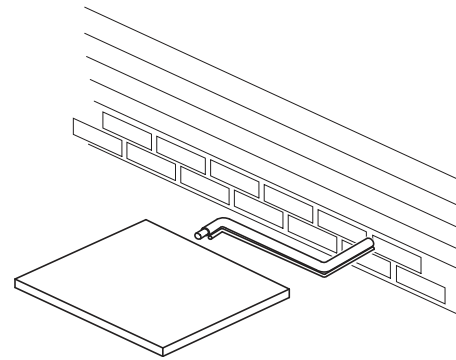

Figure 5-3

## 6 REFRIGERANT LINE ROUTING

### 6.1 Precautions

**💡 NOTE**

Take precautions to prevent noise within the building structure due to vibration transmission from the refrigerant lines. For example:

- When the refrigerant lines have to be fastened to floor joists or other framing in a structure, use isolation type hangers.
- Isolation hangers should also be used when refrigerant lines are run in stud spaces or enclosed ceilings.
- Where the refrigerant lines run through a wall or sill, they should be insulated and isolated.
- Isolate the lines from all ductwork.
- Minimize the number of 90° turns.
- Use PVC piping as a conduit for all underground installations as shown in Figure 15. Buried lines should be kept as short as possible.
- The lines should not obstruct service access to the coil, air handling system or filter.
- Care must also be taken to isolate the refrigerant lines to minimize noise transmission from the equipment to the structure.

Comply with National, State, and Local codes when isolating linesets from joists, rafters, walls, or other structural elements.



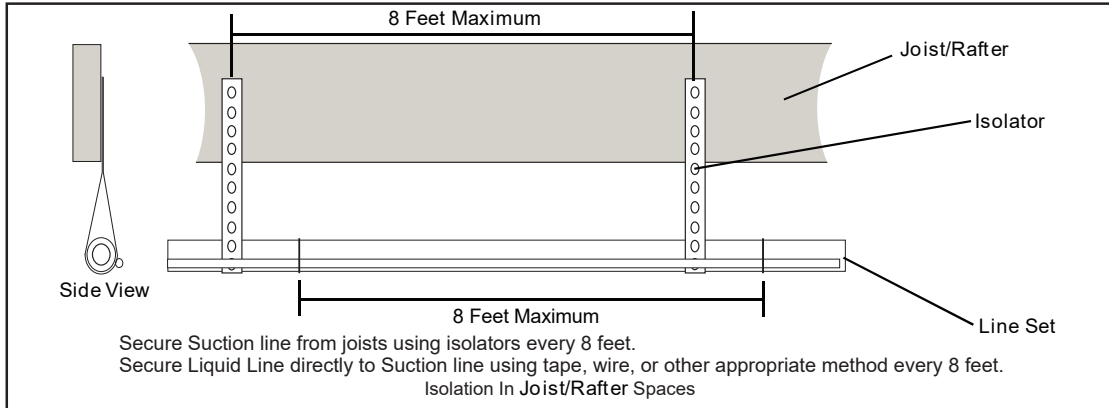

Figure 6-1

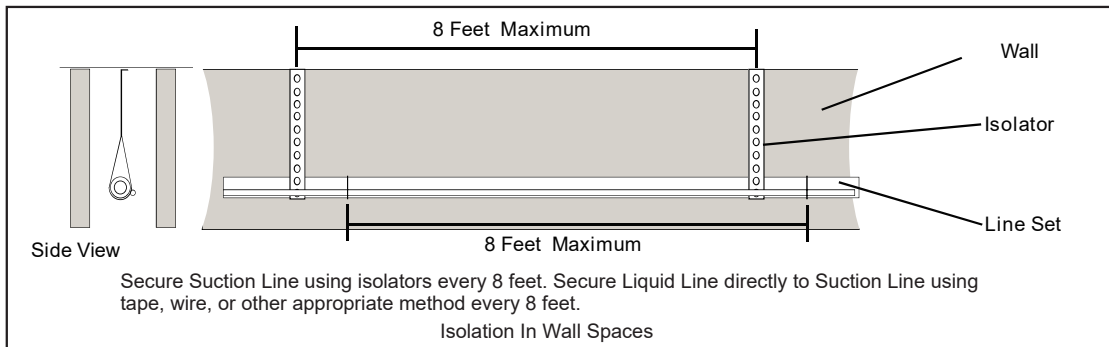

Figure 6-2

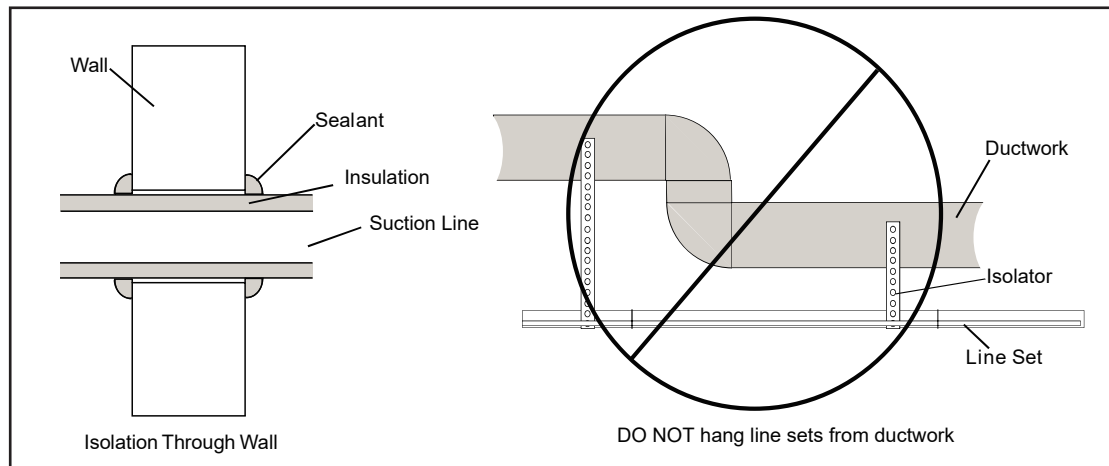

Figure 6-3

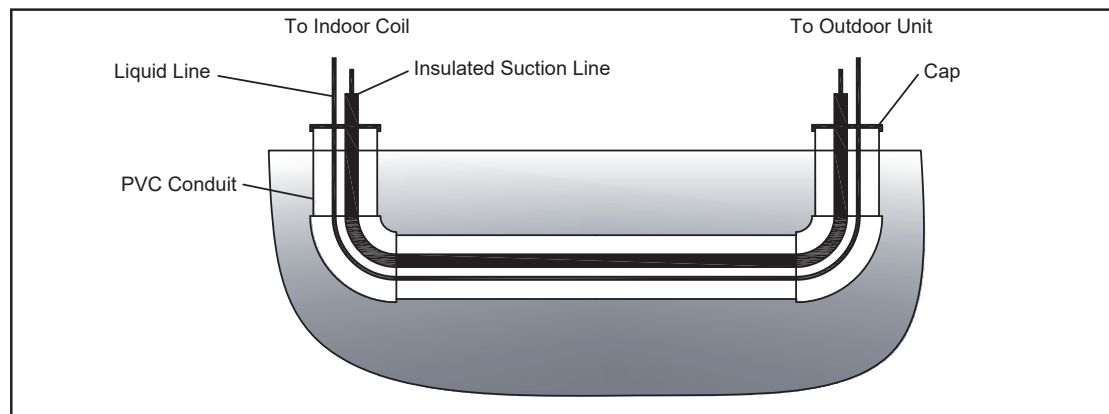

Figure 6-4

## 7 REFRIGERANT LINE BRAZING

### 7.1 Braze The Refrigerant Lines

1. Remove caps or plugs. Use a deburring tool to deburr the pipe ends. Clean both internal and external surfaces of the tubing using an emery cloth.

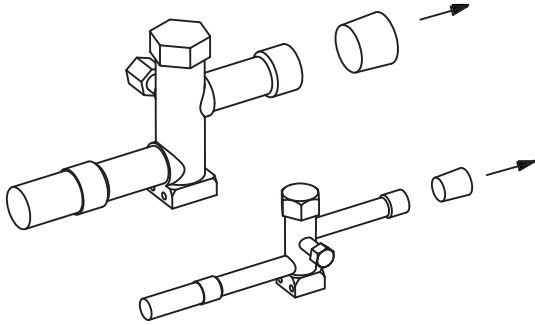

Figure 7-1

2. Remove the pressure tap cap from both service valves.

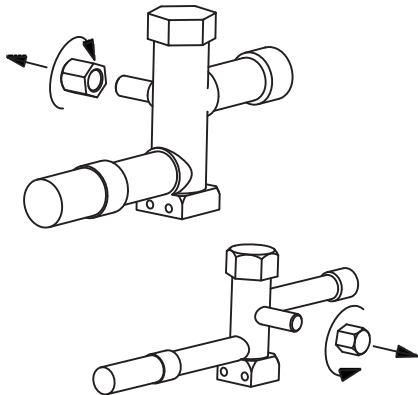

Figure 7-2

3. Purge the refrigerant lines and indoor coil with dry nitrogen.

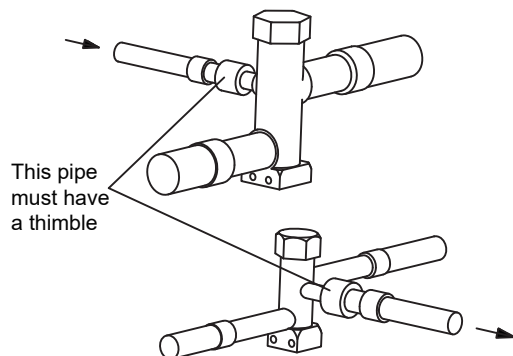

Figure 7-3

4. Wrap a wet rag around the valve body to avoid heat damage and continue the dry nitrogen purge (Fig. 7-4).

Braze the refrigerant lines to the service valves.

Check liquid line filter drier's directional flow arrow to confirm correct direction of refrigeration flow (away from outdoor unit and toward evaporator coil) as illustrated. Brazing the filter drier to the Liquid Line.

Continue the dry nitrogen purge. Do not remove the wet rag until all brazing is completed.

#### NOTE

Remove the wet rag before stopping the dry nitrogen purge.

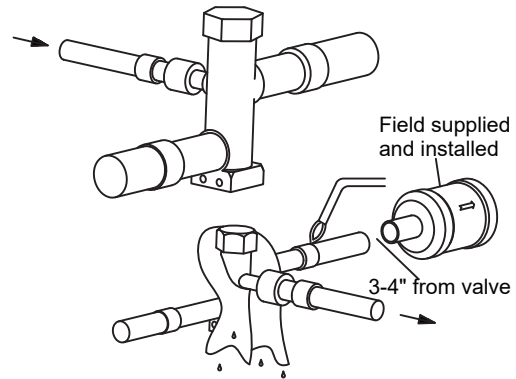

Figure 7-4

5. Replace the pressure tap caps after the service valves have cooled.

#### NOTE

Do not over tighten (between 40 and 60 inch-lbs. maximum).

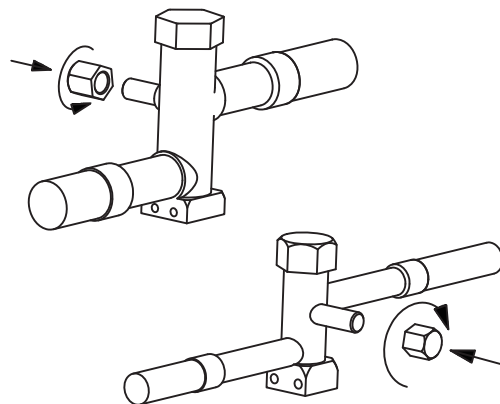

Figure 7-5

## 8 REFRIGERANT LINE LEAK CHECK

### 8.1 Check For Leaks

1. Pressurize the refrigerant lines and evaporator coil to 150 PSIG using dry nitrogen.

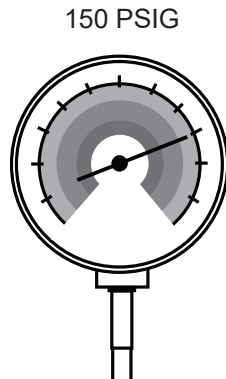

Figure 8-1

2. Check for leaks by using a soapy solution or bubbles at each brazed location.

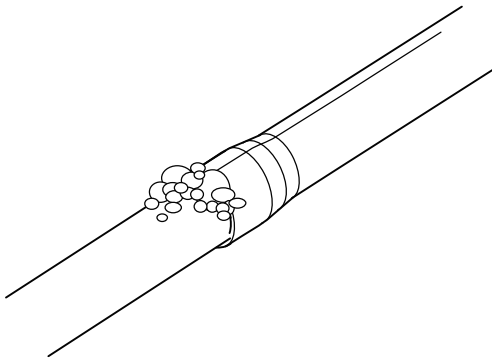

Figure 8-2

Remove nitrogen pressure and repair any leaks before continuing.

## 9 EVACUATION

### 9.1 Evacuate the Refrigerant Lines and Indoor Coil

**NOTE**

Do not open the service valves until the refrigerant lines and indoor coil leak check and evacuation are complete.

1. Evacuate until the micron gauge reads no higher than 350 microns, then close off the valve to the vacuum pump.

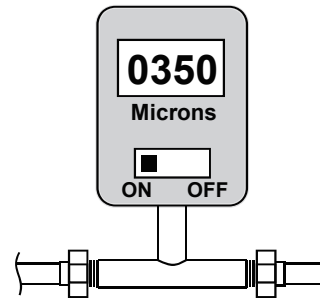

Figure 9-1

2. Observe the micron gauge. Evacuation is complete if the micron gauge does not rise above 500 microns in one (1) minute.

Once evacuation is complete turn off the vacuum pump and micron gauge, and close the valves on the manifold gauge set.



Figure 9-2

## 10 SERVICE VALVES

### 10.1 Open the Service Valves

**⚠ WARNING**

Extreme caution should be exercised when opening the Liquid Line Service Valve. Turn counterclockwise until the valve stem just touches the rolled edge. No torque is required. Failure to follow this warning will result in abrupt release of system charge and may result in personal injury and/or property damage.

**💡 NOTE**

Leak check and evacuation must be completed before opening the service valves.

1. Remove Service Valve Cap (Fig. 10-1).
2. Fully insert hex wrench into the stem and back out counterclockwise until valve stem just touches the rolled edge.
3. Replace the valve stem cap to prevent leaks. Tighten finger tight plus an additional 1/6 turn.

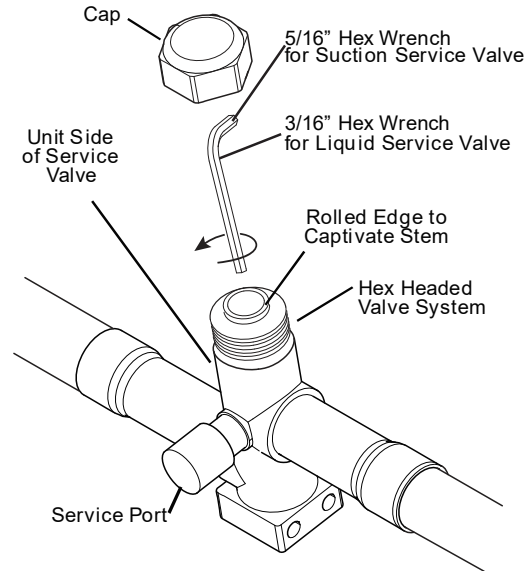

Figure 10-1

## 11 ELECTRICAL - LOW VOLTAGE

### 11.1 Low Voltage Maximum Wire Length

Table 11-1 Defines the maximum total length of low voltage wiring from the outdoor unit to the indoor unit and to the thermostat.

24 Volts - Wire Size	Max. Wire Length
18 AWG	150 Ft.
16 AWG	225 Ft.
14 AWG	300 Ft.

Table 11-1

### 11.2 Low Voltage Hook-up Diagrams

Air Handler Hook-up Diagram

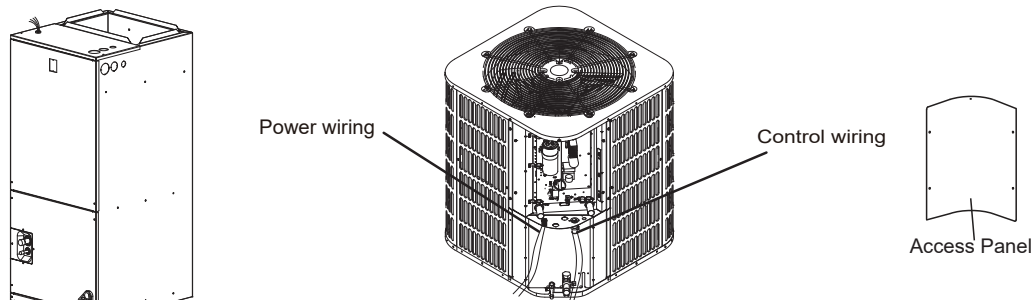

Low Voltage connection must be made inside the outdoor unit case.

Figure 11-1

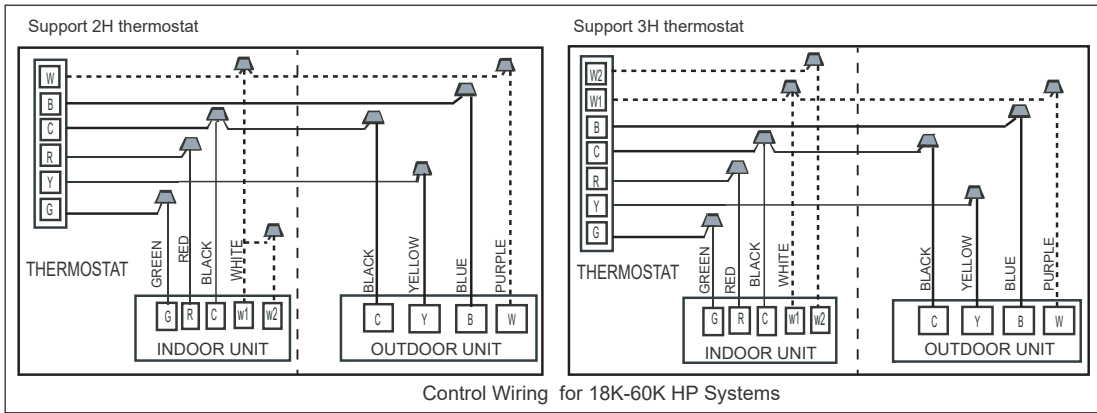

Figure 11-2

Notes: "-----" The electric auxiliary heat connection (optional).

W : Electric auxiliary heat signal.

W1 : The first Electric auxiliary heat signal.

W2 : The second Electric auxiliary heat signal.

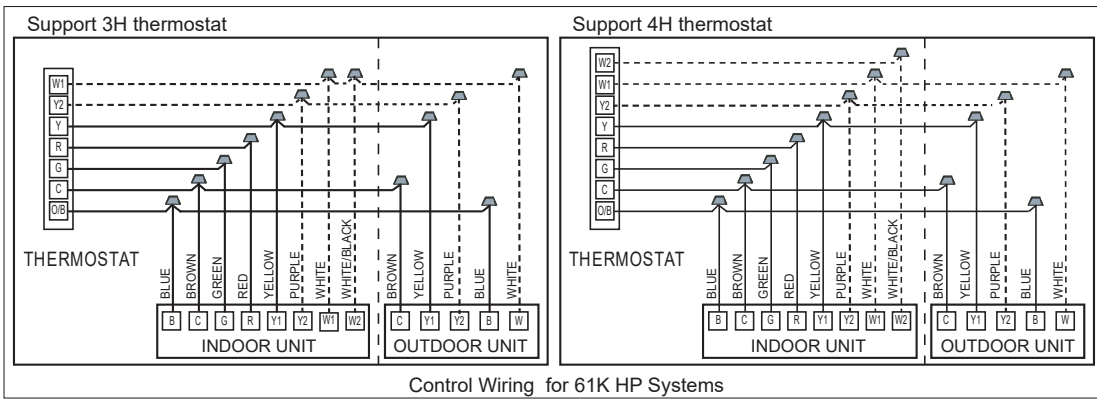

Figure 11-3

Notes: "----" The electric auxiliary heat connection (optional).

W : Electric auxiliary heat signal, connect to the Electric auxiliary heat or the first Electric auxiliary heat.

W1 : The first Electric auxiliary heat signal.

W2 : The second Electric auxiliary heat signal.

Y2 : The second cooling signal, only for 61K HP system.

Y1 and Y2 of INDOOR UNIT : Only for 61K HP system.

**WARNING**

Low Voltage line must be connected inside the outdoor unit case through control wiring channel on the right. High Voltage line must be connected through power wiring channel on the left. Mixed channel may result in personal injury.

1. During installation or maintenance, the tie of rubber ring on the electric control box shall not be cut with scissors. It can be untied by pressing the loose buckle. The tightening belt can be reused.

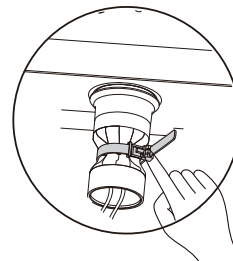
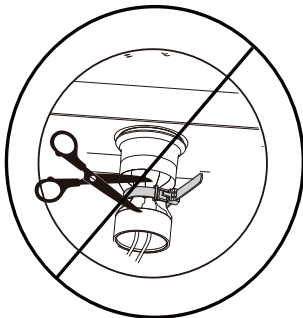

2. After installation or maintenance, the tie or rubber ring should be tightened, do not loose or discarded; the control box access panel must be installed and the screws must be tightened.

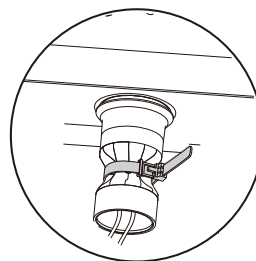
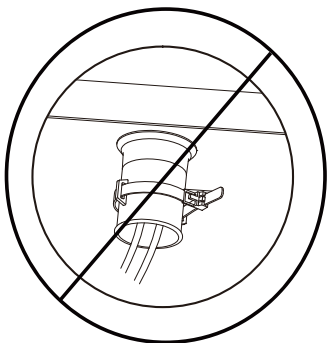

## 12 ELECTRICAL - HIGH VOLTAGE

### 12.1 High Voltage Power Supply

#### **⚠ WARNING**

##### **LIVE ELECTRICAL COMPONENTS!**

During installation, testing, servicing, and trouble shooting of this product, it may be necessary to work with live electrical components. Failure to follow all electrical safety precautions when exposed to live electrical components could result in death or serious injury.

The high voltage power supply must agree with the equipment nameplate.

Power wiring must comply with National, State and Local Codes.

Follow instructions on unit wiring diagram located on the

### 12.2 High Voltage Disconnect Switch

Install a separate disconnect switch at the outdoor unit.

Field provided flexible electrical conduit must be used for high voltage wiring.

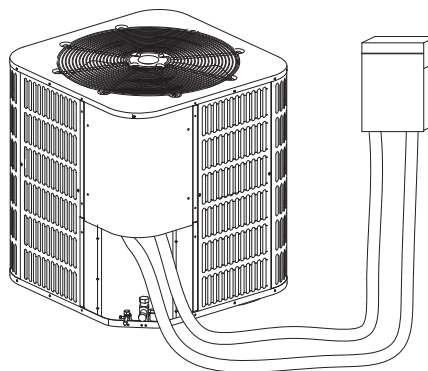

Figure 12-2

### 12.3 High Voltage Ground

## 13 START UP

### 13.1 System Start Up

1. Ensure Sections 7, 8, 9, 10, 11, and 12 have been completed.
2. Set System Thermostat to OFF.

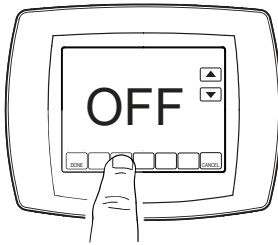

Figure 13-1

3. Turn on disconnect to apply power to the indoor and outdoor units.

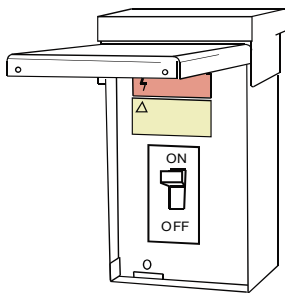

Figure 13-2

4. Wait one (1) hour before starting the unit if compressor crankcase heater is used and the outdoor ambient temperature is below 70 °F.



Figure 13-3

5. Set system thermostat to ON.

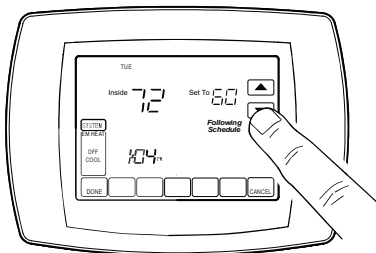

Figure 13-4

## 14 SYSTEM CHARGE ADJUSTMENT

### 14.1 Charging: Weigh-In Method

Weigh-In method can be used for the initial installation, or anytime a system charge is being replaced. Weigh-In Method can also be used when power is not available to the equipment site or operating conditions (indoor/outdoor temperatures) are not in range to verify with the suction line pressure charging method.

Model	Factory Charge	Charge multiplier for liquid line length		
		5/16"	3/8"	1/2"
All models	The data on nameplate	0.4 oz/ft	0.6 oz/ft	1.2 oz/ft

Table 14-1

#### NOTE

The factory charge in the outdoor unit is sufficient for 15 feet of standard size interconnecting liquid line.

New Installations — Calculating additional charge for lineset greater than 15 feet.

1. Total Line Length (ft) = \_\_\_\_\_(a)
2. Standard Lineset (ft) = 15 (b)
3. (a) minus (b) = \_\_\_\_\_(c)
4. Refrigerant Multiplier = \_\_\_\_\_(d)
5. Refrigerant Adder (c\*d) = \_\_\_\_\_(e)\*

\*If lineset is less than 15 feet, (e) = 0

Sealed-System Repairs — Calculating total system charge.

1. Total Line Length (ft) = \_\_\_\_\_(a)
2. Standard Lineset (ft) = 15 (b)
3. (a) minus (b) = \_\_\_\_\_(c)
4. Refrigerant Multiplier = \_\_\_\_\_(d)
5. Refrigerant Adder (c\*d) = \_\_\_\_\_(e)\*
6. Factory Charge (nameplate) = \_\_\_\_\_(f)
7. Total System Charge (e+f) = \_\_\_\_\_.

\*If lineset is less than 15 feet, (e) = 0

#### NOTE

The only mode approved for validating system charge is while in Cooling Mode. Outdoor temperature must be between 55°F and 115°F with Indoor Temperature kept between 70°F and 80°F.

### 14.2 Suction Line Pressure Charging And Refrigerant Adjustment In Coiling (above 55°F outdoor temp.)

1. Check the outdoor ambient temperatures.

Suction line pressure (in cooling mode) is the only recommended method of charging above 55°F outdoor ambient temperatures.

For outdoor ambient temperatures below 55°F, use weigh-in charge method.

**NOTE**

It is important to return in the spring or summer to accurately charge the system in the cooling mode when outdoor ambient temperature is above 55°F.

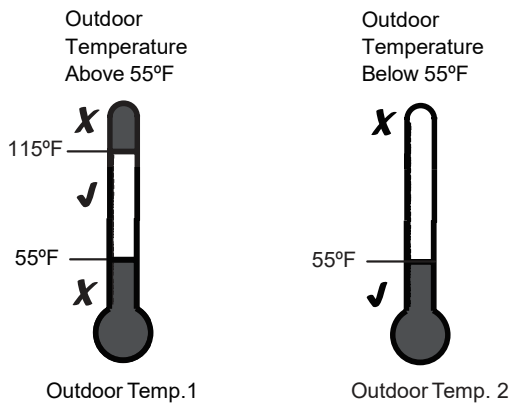

Figure 14-1

For best results the indoor temperature should be kept between 70°F to 80°F.

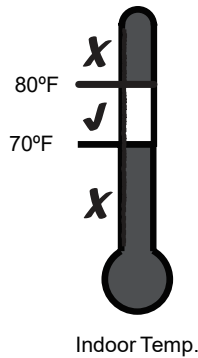

Figure 14-2

2. Ensure Sections 7, 8, 9, 10, 11, 12 and 13 have been completed.
3. Stabilize the system by operating for a minimum of 20 minutes.

**NOTE**

At startup, or whenever charge is removed or added, the system must be operated for a minimum of 20 minutes to stabilize before accurate measurements can be made.



Figure 14-3

- ▶ Measured Suction Line Pressure = \_\_\_\_\_ PSIG
- ▶ Outdoor Ambient Temperature = \_\_\_\_\_ °F
- ▶ Indoor Ambient Temperature = \_\_\_\_\_ °F
- ▶ Calculate Liquid Line Pressure = \_\_\_\_\_ PSIG
- ▶ Measured Suction Line Temperature = \_\_\_\_\_ °F

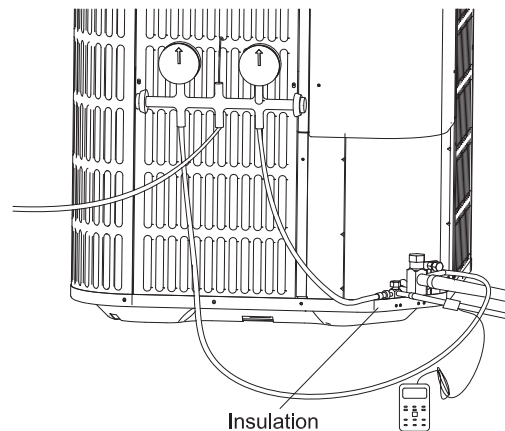

Figure 14-4



Design superheat with TXV

Outdoor DB (°F)	Indoor Unit Inlet DB/WB (°F)					
	95/79	90/75	85/71	80/67	75/63	70/58
115	13	12	11	11	10	9
110	13	11	10	10	10	9
105	12	11	10	10	9	8
100	11	10	10	10	9	8
95	11	10	10	9	8	8
90	11	10	10	9	8	8
85	12	10	9	9	8	8
80	13	11	9	9	8	8
75	14	12	9	8	7	5
70	10	9	8	6	5	5
65	7	6	6	6	5	5
60	6	5	5	5	5	5
55	6	5	5	5	5	5

Design superheat with piston

Outdoor DB (°F)	Indoor Unit Inlet DB/WB (°F)					
	95/79	90/75	85/71	80/67	75/63	70/58
115	16	11	6	5	5	5
110	18	13	8	5	5	5
105	20	15	10	5	5	5
100	23	17	13	7	5	5
95	25	20	15	9	5	5
90	27	22	17	12	5	5
85	29	24	19	14	8	5
80	25	20	16	11	7	5
75	22	18	14	9	5	5
70	22	18	13	8	5	5
65	21	17	13	8	5	5
60	20	16	12	7	5	5
55	19	15	11	5	5	5

Determine the final superheat value using total Line Length and Lift measured in 5.3 and the charts below

18K HP with TXV

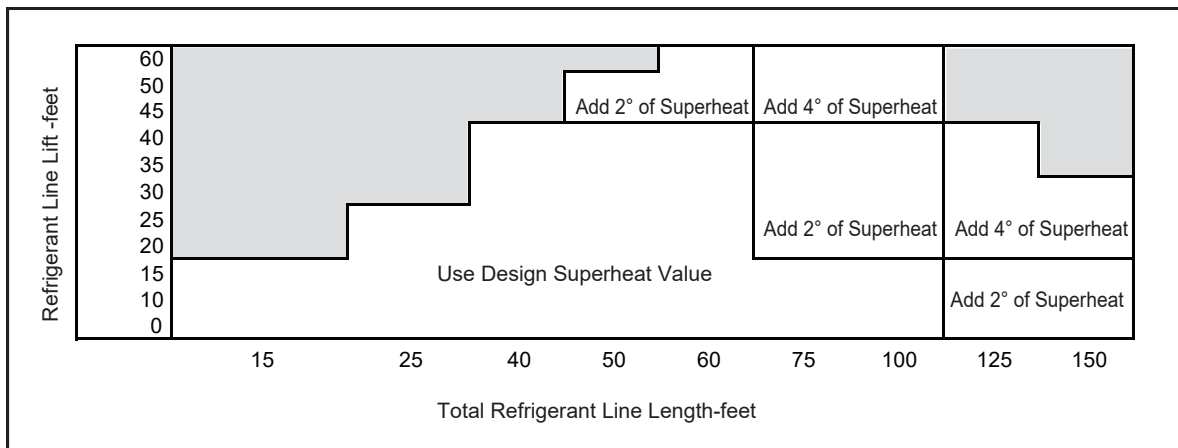

24K HP with Piston

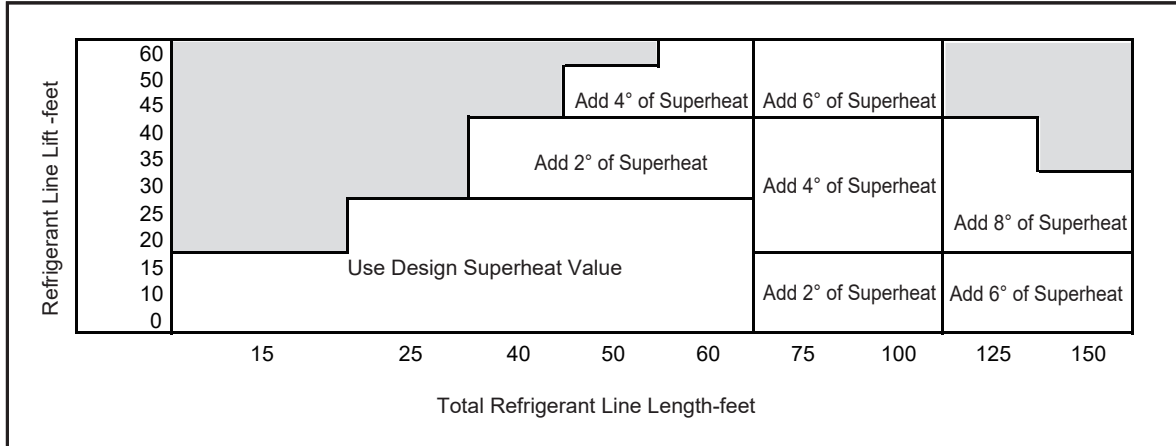

30K HP with Piston

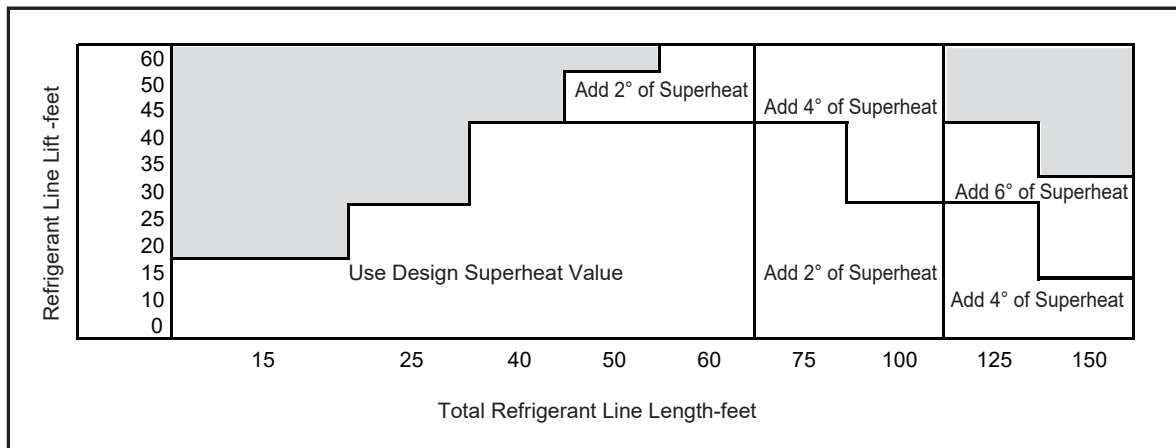

36K HP with TXV

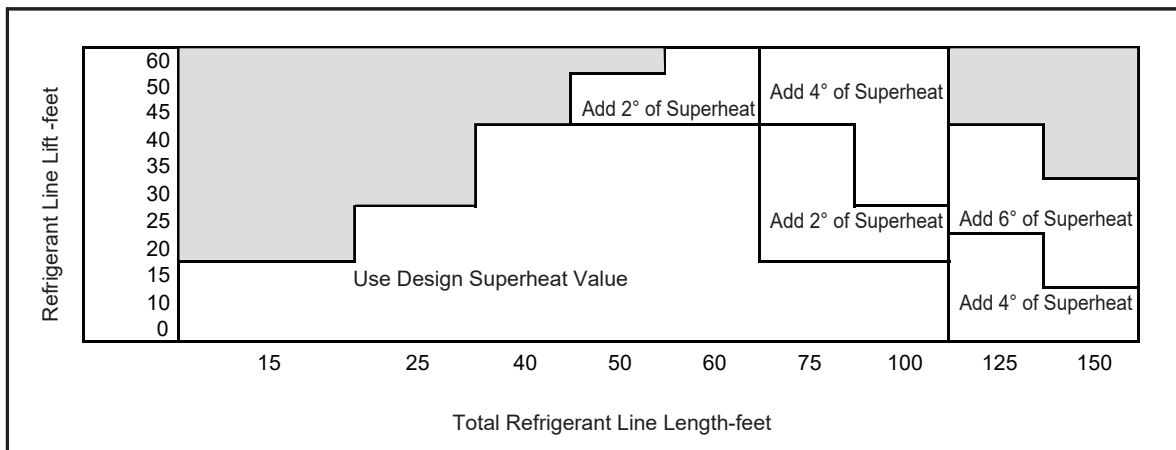

42K HP with TXV

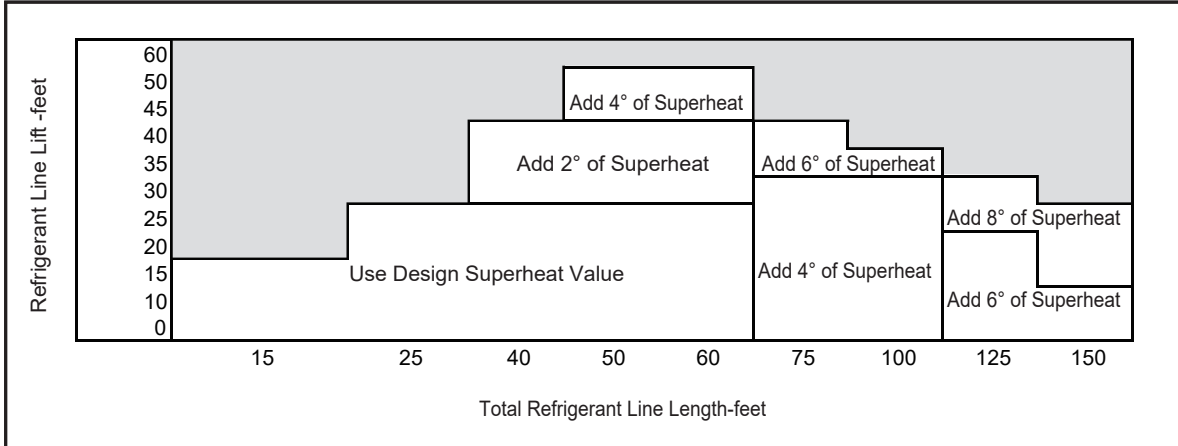

48K HP with TXV

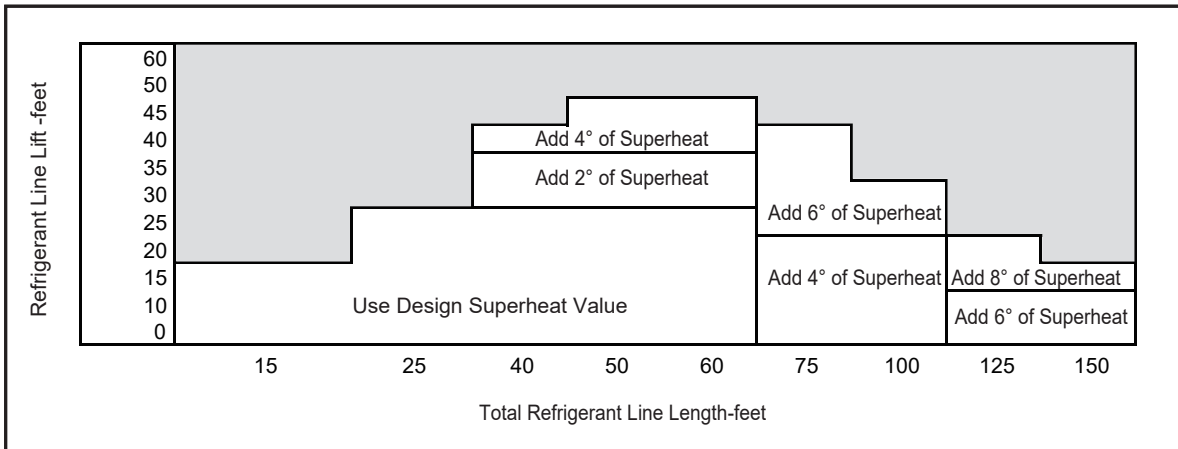

60K/61K HP with TXV

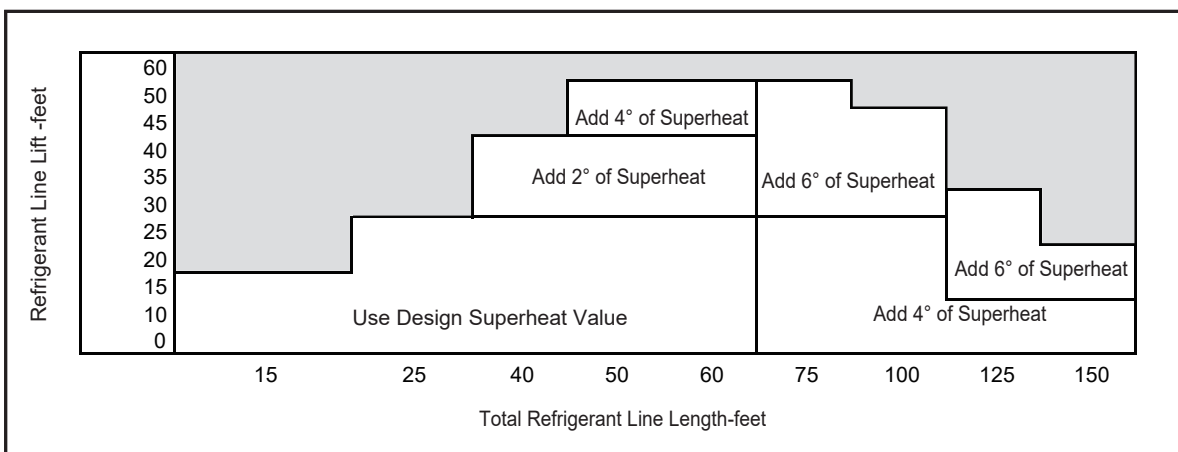

- Use the final superheat value, refrigerant temperature and pressure from STEP 4, to determine the proper suction gauge pressure using Table 14-1.

Example: Assume a 12° F final superheat value and suction temp of 58° F.

- Locate 12° F final Superheat in Table 14-1.
- Locate the Suction Temperature (58° F) in the left column.
- The Suction Gage Pressure should be approximately 133 PSIG. (This is the shown as the intersection of the Final Superheat column and the Suction Temperature row.

Design Superheat Value = \_\_\_\_\_ °F

Superheat Correction = \_\_\_\_\_ °F

Final Superheat Value = \_\_\_\_\_ °F

R410A Refrigerant Superheat Chart							
Suction Temp (°F)	Final Superheat (°F)						
	6	8	10	12	14	16	18
Suction Gauge Pressure (PSI)							
40	105	101	97	93	89	86	82
42	109	105	101	97	93	89	86
44	114	109	105	101	97	93	89
46	118	114	109	105	101	97	93
48	123	118	114	109	105	101	97
50	128	123	118	114	109	105	101
52	133	128	123	118	114	109	105
54	138	133	128	123	118	114	109
56	143	138	133	128	123	118	114
58	148	143	138	133	128	123	118
60	153	148	143	138	133	128	123
62	159	153	148	143	138	133	128
64	164	159	153	148	143	138	133
66	170	164	159	153	148	143	138
68	176	170	164	159	153	148	143
70	182	176	170	164	159	153	148
72	188	182	176	170	164	159	153

Table 14-1

- Adjust refrigerant level to attain proper final superheat.

**NOTE**

**Add refrigerant** if the measured superheat is higher than the final superheat value.

- Connect gages to refrigerant bottle and unit as illustrated (Fig. 14-5).
- Purge all hoses.
- Open bottle.
- Stop adding refrigerant when gas line pressure matches the Refrigerant Charging Chart.

**NOTE**

**Recover refrigerant** if the measured superheat is lower than the final superheat value.

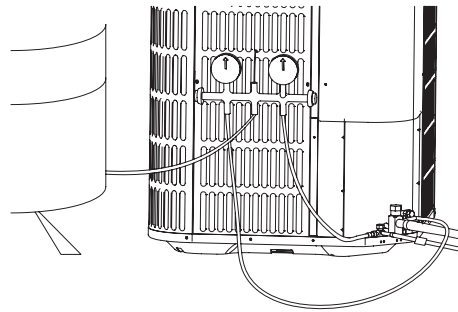

Figure 14-5

- Stabilize the system.
  - Wait 20 minutes for the system condition to stabilize between adjustments.

**NOTE**

When the gas line pressure match the chart, the system is properly charged.

- Remove gages.
- Replace service port caps to prevent leaks. Tighten finger tight plus an additional 1/6 turn.



Figure 14-6

- Record system information for reference Table 14-2. Record system pressures and temperatures after charging is complete.

Description	Value
Outdoor model number	
Measured Outdoor Ambient	°F
Measured Indoor Ambient	°F
Liquid Gage Pressure	PSIG
Suction Gage Pressure	PSIG
Suction Line Temperature	°F

Table 14-2

## 15 SYSTEM OPERATION AND TROUBLESHOOTING

### 15.1 Compressor Crankcase Heater (CCH)

The crankcase heating start must meet two conditions:

- A. Outdoor temperature  $< 37.4^{\circ}\text{F}$
- B. At power up or if the compressor has been off for more than 3 hours

The crankcase heating stop must meet the following condition:

Outdoor temperature  $> 44.6^{\circ}\text{F}$  or compressor starts.

### 15.2 Reversing Valve

Reversing valve energizes at the heating conditions, and cuts off at the cooling condition.

### 15.3 Protection Function

Reversing valve energizes at the heating conditions, and cuts off at the cooling condition.

- T3 = Outdoor Coil Temperature  
T3  $> 143.6^{\circ}\text{F}$ , compressor stops working  
T3  $< 125.6^{\circ}\text{F}$ , compressor starts working T4 =
- Ambient Temperature  
T4  $< 5^{\circ}\text{F}$ , compressor can't start  
T4  $> 10.4^{\circ}\text{F}$ , compressor starts working  
If  $32^{\circ}\text{F} \leq \text{T4} \leq 120^{\circ}\text{F}$ , unit can operate in cooling  
If  $5^{\circ}\text{F} \leq \text{T4} \leq 75^{\circ}\text{F}$ , unit can operate in heating

#### NOTE

When  $\text{T4} < 5^{\circ}\text{F}$ , the outdoor unit would provide a signal to drive up the heater installed in the indoor unit.

- Discharge temperature protection  
Discharge temperature  $> 239^{\circ}\text{F}$ , compressor stops working.  
Discharge temperature  $< 167^{\circ}\text{F}$ , compressor starts working.
- High pressure protection  
High pressure  $> 638$  PSIG, compressor and outdoor fan motor stop working.  
High pressure  $< 464$  PSIG, compressor and outdoor fan motor start working (3 minutes delay necessary).
- Low pressure protection  
Low pressure  $< 21$  PSIG, compressor and outdoor fan motor stop working.  
Low pressure  $> 44$  PSIG, compressor and outdoor fan motor start working (3 minutes delay necessary).

#### NOTE

In stand-by status, the compressor will not start in low pressure protection. Within 30 minutes, if 4 protection cycles occur. The system will be locked. It will be restore after power cycle.

### 15.4 Defrost Mode

Manual defrost mode

When the switch SW3-1 is set to "ON", the system turns to the defrost mode. The defrost mode exits by the logic of shut-down conditions of defrost mode.

#### NOTE

Once the manual defrost mode is finished, please turn the switch SW3-1 back to "off".

Start-up conditions of defrost mode

When SW3-3 switch is set to "ON" (Fig. 2-4), the mode will start up in any of the following conditions:

- Compressor operates and  $\text{T3} < 32^{\circ}\text{F}$  for a period of 30 minutes.
- $\text{T3} < 28.4^{\circ}\text{F}$  and compressor operates for the first time after connected to the power source.
- When  $\text{T3} < 28.4^{\circ}\text{F}$  and the system is on standby for two hours continuously.

When SW3-3 switch is set to "OFF" (Fig. 14-6), the mode will start up in any of the following conditions:

- Compressor operates and  $\text{T3} < 32^{\circ}\text{F}$  for a period of 60 minutes.
- $\text{T3} < 28.4^{\circ}\text{F}$  and compressor operates for the first time after connected to the power source.
- When  $\text{T3} < 28.4^{\circ}\text{F}$  and the system is on standby for two hours.

Shut-down conditions of defrost mode:

The mode will shut down in any of the following conditions:

- The defrosted time lasts 10 minute.
- $\text{T3} \geq 64.4^{\circ}\text{F}$  and  $\text{T4} \geq 28.4^{\circ}\text{F}$ .
- Compressor stops operating.
- $\text{T3} \geq 64.4^{\circ}\text{F}$  lasts 60 seconds when  $\text{T4} < 28.4^{\circ}\text{F}$ .

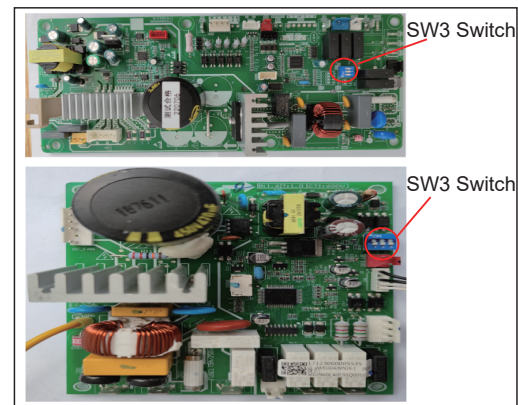

Figure 15-1

## 15.5 Two-stage Compressor (61K HP only)

The 61K HP Systems feature a Two-stage scroll compressor which is controlled by Y1 and Y2.

- Y1: 24VAC thermostat input for first stage operation of the unit.
- Y2: 24VAC thermostat input/output for second stage operation of the unit.

If the control receives a call for second-stage compressor operation Y2 in heating or cooling mode and the first-stage compressor output is active, the second-stage compressor solenoid output will be energized by the unit control system operation function.

The unit control de-energizes the second-stage compressor solenoid output immediately when the Y2 signal is removed or the first-stage compressor output is de-energized for any reason.

## 15.6 Temperature Sensor Resistance Table

Temperature °F	Resistance kΩ	Temperature °F	Resistance kΩ	Temperature °F	Resistance kΩ	Temperature °F	Resistance kΩ
-4	106.73	37	29.87	78	10	119	3.69
-3	103.25	38	29.22	79	9.5	120	3.61
-2	99.89	39	28.19	80	9.26	121	3.53
-1	96.65	40	27.39	81	9.03	122	3.45
0	93.53	41	26.61	82	8.81	123	3.38
1	90.53	42	25.85	83	8.59	124	3.3
2	87.62	43	25.12	84	8.38	125	3.23
3	84.83	44	24.42	85	8.17	126	3.16
4	82.13	45	23.73	86	7.97	127	3.1
5	79.52	46	23.07	87	7.78	128	3.03
6	77.01	47	22.42	88	7.59	129	2.96
7	74.58	48	21.8	89	7.4	130	2.9
8	72.24	49	21.2	90	7.22	131	2.84
9	69.98	50	20.61	91	7.05	132	2.78
10	67.8	51	20.04	92	6.88	133	2.72
11	65.69	52	19.49	93	6.72	134	2.67
12	63.65	53	18.96	94	6.56	135	2.61
13	61.68	54	18.44	95	6.4	136	2.56
14	59.78	55	17.94	96	6.25	137	2.5
15	57.95	56	17.45	97	6.1	138	2.45
16	56.17	57	16.98	98	5.96	139	2.4
17	54.46	58	16.52	99	5.82	140	2.35
18	52.8	59	16.08	100	5.68	141	2.3
19	51.2	60	15.65	101	5.55	142	2.25
20	49.65	61	15.23	102	5.42	143	2.21
21	48.16	62	14.83	103	5.3	144	2.16
22	46.71	63	14.43	104	5.18	145	2.12
23	45.31	64	14.05	105	5.06	146	2.08
24	43.95	65	13.68	106	4.94	147	2.03
25	42.64	66	13.32	107	4.83	148	1.99
26	41.38	67	12.97	108	4.72	149	1.95
27	40.15	68	12.64	109	4.61	150	1.91
28	38.97	69	12.31	110	4.51	151	1.88
29	37.82	70	11.99	111	4.41	152	1.84
30	36.71	71	11.68	112	4.31	153	1.8
31	35.64	72	11.38	113	4.21	154	1.77
32	34.6	73	11.09	114	4.12	155	1.73
33	33.59	74	10.8	115	4.03	156	1.7
34	32.61	75	10.53	116	3.94	157	1.66
35	31.67	76	10	117	3.85	158	1.63
36	30.76	77	10	118	3.77	159	1.6







Table 15-1

## 15.7 Electrical Data Table

Model	18	24	30	36	42	48	60	61
Minimum circuit ampacity (A)	13	15.5	17.2	23	26.9	29.6	34.6	37.9
Maximum circuit protector (A)	20	25	30	40	50	50	60	60



### 15.9.2 For 61K HP System

	STEADY ON	NORMAL OPERATION
	OFF	DFC FAILURE
	1FLASH	T3 SENSOR FAILURE
	2FLASH	T4 SENSOR FAILURE OR HGS OPEN
	3FLASH	LPC OPEN
	5FLASH	OFM FAILURE

## 16 WARRANTY

Assist owner with processing Warranty cards and/or online registration.

### 16.1 Maintenance

Dirt should not be allowed to accumulate on the indoor or outdoor coils or other parts in the air circuit. Clean as often as necessary to keep the unit clean. Use a brush, vacuum cleaner attachment or other suitable means.

The outdoor fan motor is permanently lubricated and does not require periodic oiling.

Refer to the furnace or air handler instructions for filter and blower motor maintenance.

The indoor coil and drain pan should be inspected and cleaned regularly to assure proper drainage.

#### NOTE

It is unlawful to knowingly vent, release or discharge refrigerant into the open air during repair, service, maintenance or the final disposal of this unit. When the system is functioning properly and the owner has been fully instructed, secure the owner's approval.

### 16.2 Removing and Installing The Cover Plate

1. Before removing the cover plate of the electronic control box, please be note the screws 1 - 7 must be removed first.

2. When installing the back cover plate of the electric control box, please be noted the screws 1 and 3 must be installed as the last step to facilitate assembly and avoid damage the waterproof sponge .

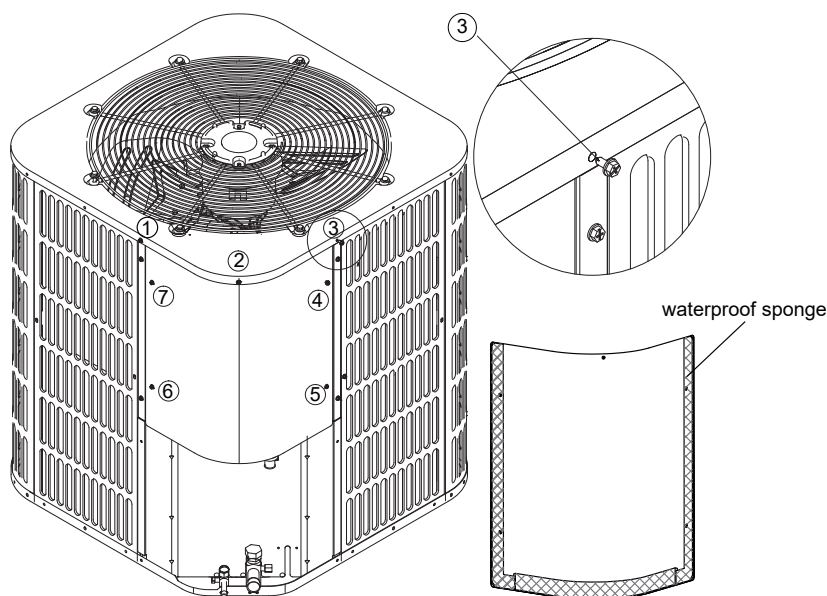

Figure 16-1



**Page Intentionally Left Blank**

**Page Intentionally Left Blank**



## SE SERIES LIMITED WARRANTY

Congratulations on purchasing your new HVAC equipment.

Your unit automatically qualifies for the warranty coverage listed below provided you meet the warranty conditions.

**APPLIES TO MODELS:** RSA\*, RSH\*, AMP\*, WMP\*, WMX\*, GFM\*, MAA\*, RHP\*, RGP\*

### YEAR 1 PRODUCT REPLACEMENT

If the heat exchanger, evaporator coil (packaged systems only), condenser coil, or compressor fails within the first year (365 days) after the date of installation to the original consumer for the original installation, the original purchase cost of the unit will be reimbursed to the authorized Comfort-Aire/Century distributor who has received prior authorization from Comfort-Aire/Century for the failure. The owner is responsible for additional labor, freight, and miscellaneous charges. Units installed in a commercial application, defined as any application other than a residential/multifamily (personal, family or household) purpose, are not eligible for the one year product replacement.

### LIMITED FIVE (5) YEAR WARRANTY

All parts, the compressor, and the heat exchanger are warranted to be free from defects in workmanship and materials for normal residential use and maintenance for five (5) years from the date of purchase by the original consumer for the original residential installation.

### LIMITED EXTENDED WARRANTY

When registered with Comfort-Aire/Century, the heat exchanger is warranted to be free from defects in material and workmanship for twenty (20) years and the compressor is warranted to be free from defects in material and workmanship for ten (10) years from the date of purchase by the original consumer for the original installation.

### DURATION OF WARRANTY

The warranty begins on the date of purchase by the original consumer (homeowner). The original consumer must retain a receipted bill of sale or invoice showing model and serial number as proof of the warranty period initiation.

### CONDITIONS FOR WARRANTY COVERAGE

Unit must be properly installed and maintained by a licensed HVAC service provider in accordance with the installation, operation, and maintenance instructions provided with each unit. Unit cannot have been subjected to accident, alteration, improper repair, neglect/misuse, or force majeure. Proof of proper maintenance over the lifetime of the unit must be supplied. Performance cannot be impaired by use of any product not authorized by Comfort-Aire/Century, or by any adjustments or adaptations to components. Serial numbers and/or rating plate have not been altered or removed. Damage has not been a result of inadequate wiring or voltage conditions, use during brown-out conditions, or circuit interruptions. Unit remains in the original residential installation and is not transferrable. Unit was not purchased over the internet or at auction. Non-approved refrigerant and/or non-approved system additives will void this warranty.

### WARRANTY EXCEPTIONS

The Limited Express Warranty does not cover costs associated with normal maintenance, utility usage, labor, shipping and handling, or collateral damage. It also does not cover any portion or component of the system that is not supplied by Comfort-Aire/Century, regardless of the cause of failure of such portion or component.

### LIMITATION OF LIABILITY

There are no other express or implied warranties. Comfort-Aire/Century makes no warranty of merchantability and does not warrant that the unit is suitable for any particular purpose, building, room size, or condition except as specifically provided in this document. There are no other warranties, express or implied, which extend beyond the description in this document. All warranties implied by law are limited in duration to the five-year term of the Parts Warranty. Your exclusive remedy is limited to the replacement of defective parts. Comfort-Aire/Century will not be liable for any consequential or incidental damages caused by any defect in this unit. This warranty gives you specific legal rights and you may also have other rights which vary from state to state. Some states do not allow a limitation on how long an implied warranty lasts or do not allow the exclusion or limitation of incidental or consequential damages, so the above limitations or exclusions may not apply to you. No warranties are made for units sold outside the continental United States and Canada. Your distributor or final seller may provide a warranty on units sold outside these areas. Comfort-Aire/Century will not be liable for damages if our performance regarding warranty resolution is delayed by events beyond our control including accident, alteration, abuse, war, government restrictions, strikes, fire, flood, or force majeure.

**Please register your new equipment to enjoy an extended warranty.**

**For Comfort-Aire:**

[www.comfort-aire.com/wps/portal/product-registration](http://www.comfort-aire.com/wps/portal/product-registration)

**For Century:**

[www.century-hvac.com/wps/portal/product-registration](http://www.century-hvac.com/wps/portal/product-registration)



### KEEP THIS INFORMATION AS A RECORD OF YOUR PURCHASE

Apply Serial Number and Model Number sticker here (from product carton). If unavailable, write serial number and model number below (can be found on unit rating plate).

\_\_\_\_\_

Date of Purchase

Date Installation Completed

Component of new HVAC system

Replacement furnace only

Remember to retain your bill of sale as proof of warranty period and ownership.

Due to ongoing product improvements, specifications and dimensions are subject to change and correction without notice or incurring obligations. Determining the application and suitability for use of any product is the responsibility of the installer. Additionally, the installer is responsible for verifying dimensional data on the actual product prior to beginning any installation preparations.

Incentive and rebate programs have precise requirements as to product performance and certification. All products meet applicable regulations in effect on date of manufacture; however, certifications are not necessarily granted for the life of a product. Therefore, it is the responsibility of the applicant to determine whether a specific model qualifies for these incentive/rebate programs.

*Comfort-Cire*®  **Century**®

1900 Wellworth Ave., Jackson, MI 49203 • Ph. 517-787-2100 • [www.marsdelivers.com](http://www.marsdelivers.com)

