

**Direct Replacement Crankcase Heaters for Copeland**

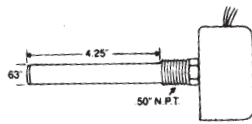
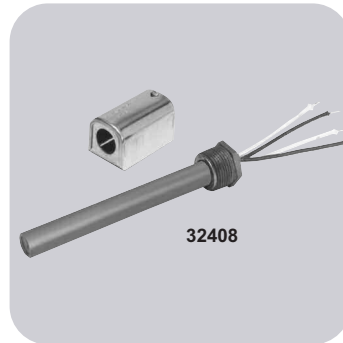

Figure 1



**Crankcase Heaters for Copeland**

NOTE: All heaters requiring clips or brackets are packaged with the appropriate clips or brackets required.

MARS NO.	COPELAND NO.	WATTS	VOLTS	HEATER LENGTH IN.	FIGURE	COMPRESSOR MODEL	ACCESSORIES
32408	518-0002-01	100	480	4.25	1	4R, 6R, 6T, 4D, 6D	-

**Self Regulating Crankcase Heaters**

MARS self-regulating crankcase heaters are designed for use with refrigeration compressors up to 5HP and 40 inches in circumference. These heating cables provide peak heat during cold periods and reduced heat when the air temperature rises and should be used in non-hazardous areas.

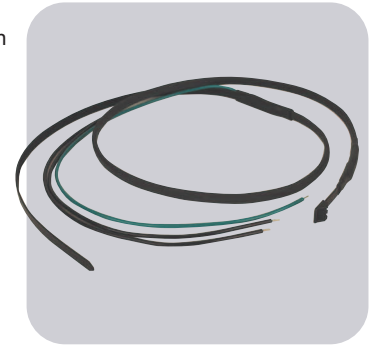

- Cold length: 30"
- Heat cable length: 50"

MARS NO.	TYPE	WATTS	VOLTS
70970	Self Regulating	32W @ 50°F • 60W @ 0°F	120
70971	Self Regulating	32W @ 50°F • 60W @ 0°F	240

**Direct Replacement Crankcase Heaters for Carrier**

Figure 1

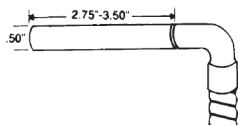

**Crankcase Heaters for Carrier**

MARS NO.	CARRIER NO.	WATTS	VOLTS	HEATER LENGTH IN.	LEAD LENGTH IN.	FIGURE	COMPRESSOR MODEL
32472	HT36FL379	125	120	2.75	60	1	EM:06DM: 306B:50EQ
32474	HT36FL479	125	240	2.75	68	1	EM:06DM: 30HR:30HS